

Firestone

The Components of Airide™ springs

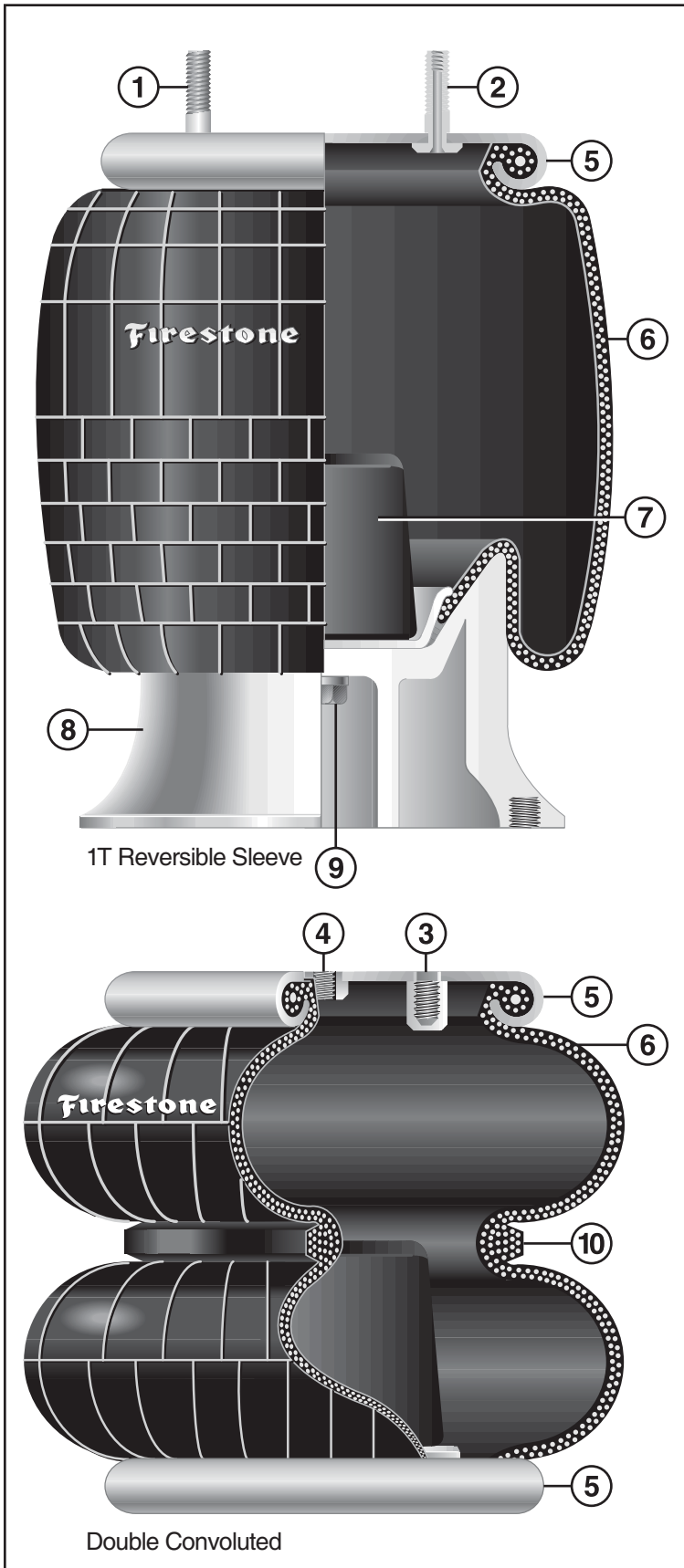

1. Stud

A permanent part of the bead plate assembly used to attach the airspring to the suspension.

2. Combo Stud

Combination mounting stud and air fitting.

3. Blind Nut

A permanent part of the bead plate assembly providing an alternate mounting system to the stud.

4. Air Fitting Hole

A tapped hole usually 1/4" N.P.T. providing air entrance for the part.

5. Bead Plate

Permanently crimped onto the bellows at the factory allowing complete part leak testing prior to shipment.

6. Bellows

The heart of an Airide spring. Includes at least four plies, or layers, of material—an inner layer, two plies of cord-reinforced fabric, and an outer layer.

7. Bumper (Optional)

A solid molded rubber fail-safe device used on many suspension applications. Prevents excessive damage to vehicle and suspension in the case of sudden air pressure loss.

8. Piston

The lower section of the 1T and 1X style of airspring made from aluminum, steel or fiber reinforced plastic. Provides lower mounting arrangement for the airspring in the form of tapped holes or studs.

9. Piston Bolt

Attaches the piston to the bellows assembly. Extended, in some cases, to serve as a means of attaching the spring to the suspension.

10. Girdle Hoop

A ring between the convolutions of the convoluted-type air spring.

Service Assembly

On Firestone Airide springs of the 1T style, the rubber bellows bead plate portion of the spring is a separate hermetically sealed unit, available for replacement use without the piston. Called a "service assembly," it includes a bead plate, bellows, internal bumper (if any), and all attaching hardware.